

API

DYNAMIC 9D LADAR





9D LASER DETECTION AND RANGING SYSTEM:

THE NEW STANDARD FOR AUTOMATED, NON-CONTACT, OPTICAL
DIMENSIONAL METROLOGY

API's 9D LADAR (Laser Detection And Ranging) captures both dimensional and surface geometry data and incorporates a breakthrough technology that is set to revolutionize automated production measurements. The patent-pending 9D LADAR offers the novel interferometry-based non-contact measurement system incorporating Optical Frequency Chirping Interferometry (OFCI) technology. API's OFCI technology uses 20 kHz speed fast laser chirping to generate a wide spectrum for optical interference. The interference signal detected, using the time series detection method yields 100x higher sensitivity than the phase-detection method.

9D LADAR "GAME-CHANGING" TECHNOLOGY

DYNAMIC 9D LADAR uses API's (patent pending) Optical Frequency Chirping Interferometer (OFCI) technology, developed over a 15-year period, with major sub-components designed for maximum performance and reliability. 9D LADAR provides micron-level resolution while eliminating issues associated with surface reflectivity, slow data acquisition speeds, limited accuracies, restrictive incident angles, and susceptibility to production environment noise.



- 9D LADAR captures both dimensional and surface geometry data targeting all manufacturing industries including but not limited to; automotive, aerospace, ship building, energy, transportation, machine tool, robotics and construction.
- 9D LADAR outperforms traditional, off-line, large volume coordinate measuring machines (CMM) and near-line and in-line inspection solutions using conventional Laser Radar, optical laser-line and structured light scanning systems.
- 9D LADAR systems process measured data at the impressive rate of 20,000 points per second and with scanning speeds of 0.2 seconds/cm².
- 9D LADAR'S high dynamic range is insensitive to the measured parts' reflectivity, can measure translucent materials, and is able to measure desired part features with up to an 85-degree incidence angle.
- High-density raster scanning delivers up to 50 lines/second, with 0.1mm line spacing. 9D LADAR'S on-board scale reference system delivers unparalleled 2D and 3D accuracies of 6 μm/m providing comparable accuracies to benchmark accuracy large volume CMMs.
- 9D LADAR'S compact design, weighing just 10.4 kg, incorporates an integral controller with ethernet communication, allowing for seamless integration to both portal CMM frames or 6-axis industrial robots, including 7-axis rail mounted configurations.

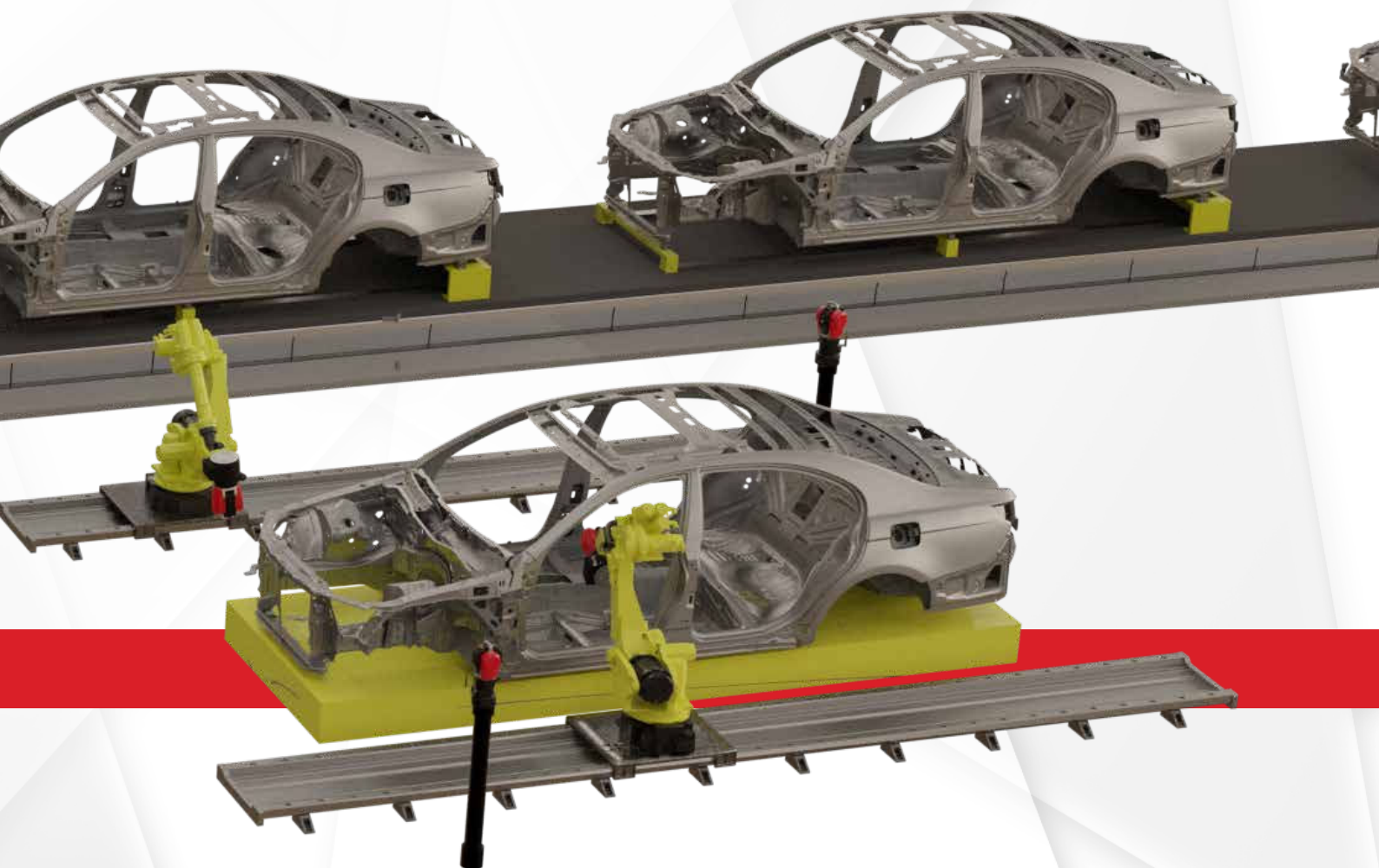

9D LADAR COLOR SCAN FUNCTIONALITY

- 9D LADAR delivers X, Y, Z, and I, J, K data for each generated cloud point along with the addition of R,G,B, (Red, Green, Blue) data allowing for scanned data to be imaged directly onto the captured camera image. This unique capability allows features with distinct background color contrast, surface vectors, surface roughness etc, where it is difficult to isolate with only the standard 3D point cloud data.
- The RGB data contained within the generated point cloud allows a full color representation of the scanned part with associated fidelity, highlighting surface discrepancies, and replicating the authentic color of the physical part.
- Some measurement applications also require the measurement of points at designated part identification-marks, which are not identified in CAD, allowing the user to program the semi-automatic identification of marks and thereafter apply an automated macro-measurement process. The generated RGB data can also be automatically utilized for setting part alignment of a freeform surface where the part edge can be identified by color such as in laminated films.

9D LADAR OUTPERFORMS CONVENTIONAL LASER RADAR

API's proprietary frequency-chirp interferometer was designed to overcome chronic problems of existing Laser Radar systems in the market.

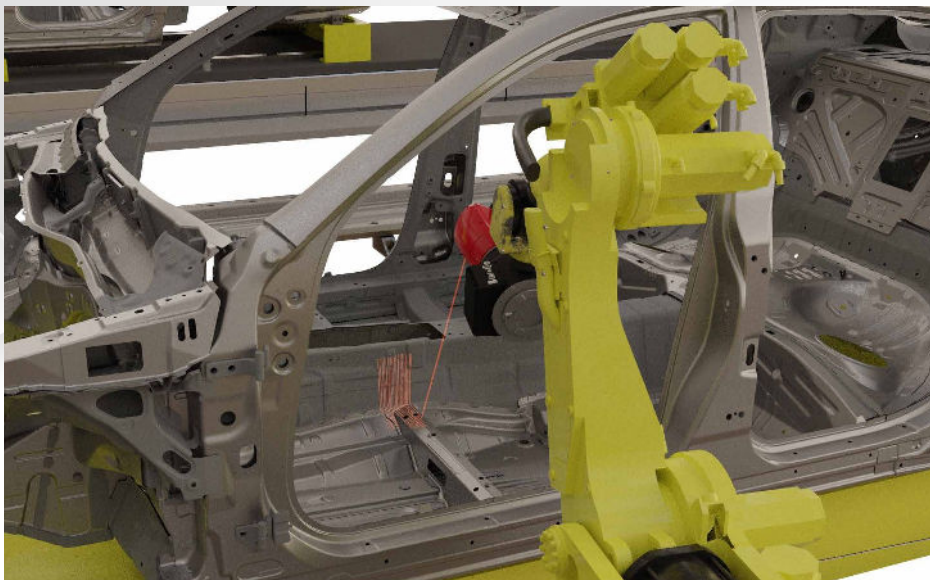

9D LADAR PERFORMANCE COMPARISON WITH CONVENTIONAL LASER RADAR

	CONVENTIONAL LASER RADAR SYSTEMS	API 9D LADAR SYSTEMS	IMPROVMENT
Core Technology	Frequency-Modulated Coherent Laser	Optical Frequency Chirping Interferometry	✓
Data Rate	500pts/sec-1,000pts/sec Maximum	20,000pts/sec	✓
Scanning Speed	1 sec/cm ² Maximum	0.2 sec/cm ²	✓
Raster Scanning	N/A	50 lines/sec - 0.1 mm spacing	✓
Volumetric Accuracy (MPE)	Linear: 20µm + 5µm/m 3D: 20µm +14.5µm/m	Linear: 25µm + 2µm/m 3D: 25µm + 6µm/m	✓
Beam Spot Size	Sub-mm	32µm or smaller	✓
Target Reflectivity	Sensitive	Insensitive	✓
Incident Angle	≥ 45-degree	≥ 85-degree	✓
Translucency	Inability to measure translucent objects	Measurement of translucent objects	✓
Control System	External	Internal	✓

9D LADAR ADVANCED FEATURES

- 9D Ladar mounted on an industrial robot can be tracked real-time using API's 6DoF RADIANT Laser Tracker. Exact 6DoF positioning of the 9D Ladar's measurements provides unlimited precision robot poses.
- LADAR'S iVision smart camera system provides instant part visualization for automated scan path planning, providing both automated feature and selective region measurement, along with remote measurement operation viability.
- Edge Detection
- 9D LADAR has a laser beam spot-size down to just 32µm or less and is available in 3 Laser Detection (LD) Ranges with associated stand-off distances.

LD-8: 0.5m-8m range | LD-15: 1m-15m range | LD-25: 1.5m-25m range

DYNAMIC 9D LADAR AUTOMATION DELIVERING QUALITY 4.0

For more than 30 years, API has pioneered advancements in laser-based metrology equipment for both measurement and calibration tasks. API's founder and CEO, Dr. Kam Lau, invented the Laser Tracker while working at the USA's National Institute of Standards and Technology (NIST) allowing industrial robot accuracies to be determined. API subsequently delivered the world's 1st 6DoF Laser Tracker in 1989. API also invented the 1st 6DoF Laser Interferometer for machine tool calibration, allowing all 21 parameters of a machine tool to be calibrated in a single set-up. Now, API is moving laser-based production measurements into the future by delivering Quality 4.0 automated inspection solutions with the invention of its 9D LADAR.



QUALITY 4.0 APPLICATIONS

AUTOMATED PORTABLE MEASUREMENTS

The compact size and light-weight design of API'S 9D LADAR allows the instrument to be taken directly to manufacturing locations, allowing automated measurement to be performed quickly and with minimum set-up times. Measurement variability using current manually operated tactile and optical measuring devices are eliminated with execution of all measurements automatically. Existing third-party metrology software's can be utilized for data reporting, minimizing learning curves and ensuring seamless integration into existing measurement practices and data analysis.



NEXT GENERATION ROBOTIC AUTOMATED MEASUREMENTS

Non-contact Laser Radar technology has proven its ability to measure automotive parts including full 'Body-in-White', as a replacement for CMM measurements adjacent to production lines providing both external and internal measurements of vehicle body regions. 9D LADAR precision automated high-speed 'raster' scanning provides both surface geometry point cloud data collection as well as 'gap and flush' dimensional data. Laser Radar systems, although offering advantages over CMM measurements, remained too slow to pace production thereby providing an audit only measuring function. The enhanced speed and data collection rate of 9D LADAR dramatically increases the opportunity to pace production. Systems can be installed in-line or near-line.

The new API 9D LADAR delivers the fastest ever laser measurement solution dramatically increasing measurement throughout and productivity for all automotive applications.

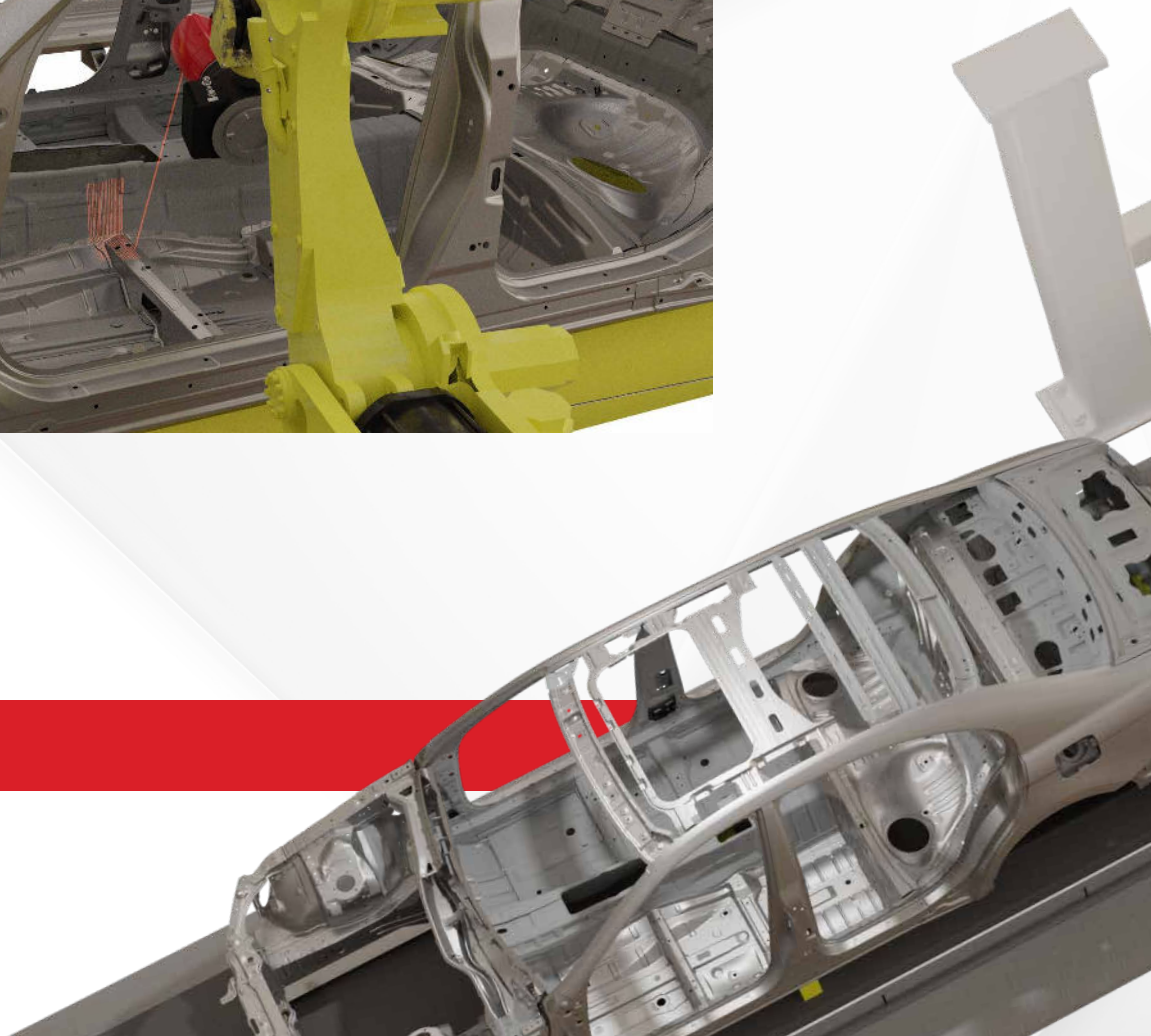
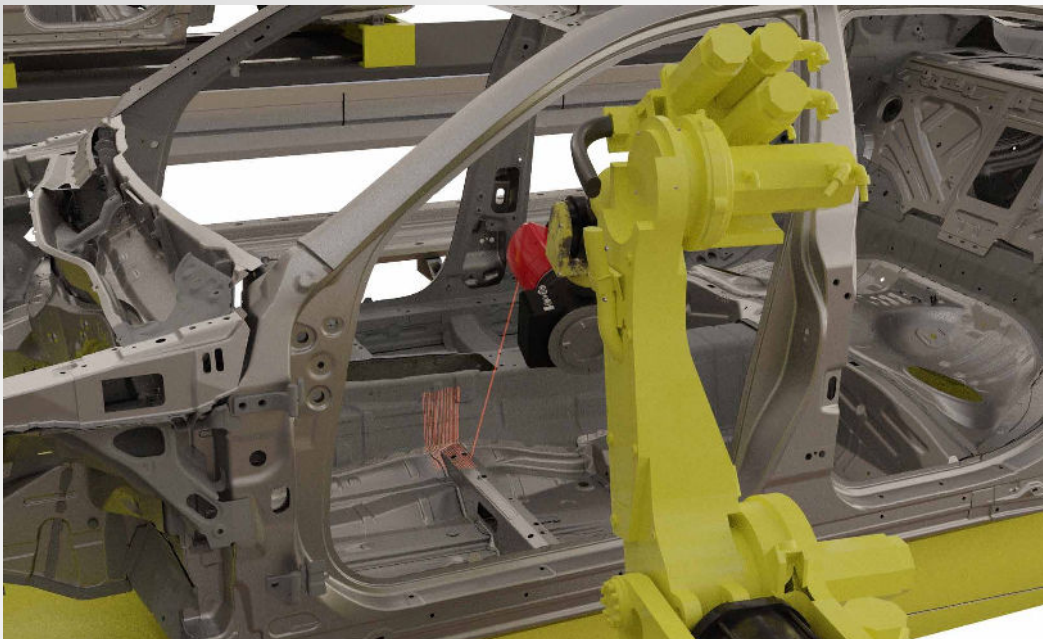

MULTI-LADAR - IN-LINE BIW INSPECTION

To-date in-line inspection of vehicle bodies has been performed by a fixed array of laser-line scanning sensors targeting specific features deemed critical to operations and providing process control rather than specific part inspection data. The high scanning speed and versatility of 9D LADAR allow an in-line inspection paradigm shift by providing a fully programmable measurement solution to be installed, delivering both complete individual car body inspection, (including critical gap and flush measurements), together with overall process control data delivering Quality 4.0 adaptive control of operations.

**"API DYNAMIC 9D LADAR
DELIVERS THE FASTEST EVER
AUTOMATED MEASUREMENT
TOOL DRAMATICALLY
INCREASING MEASUREMENT
THROUGHOUT AND
PRODUCTIVITY FOR ALL
AUTOMOTIVE APPLICATIONS"**

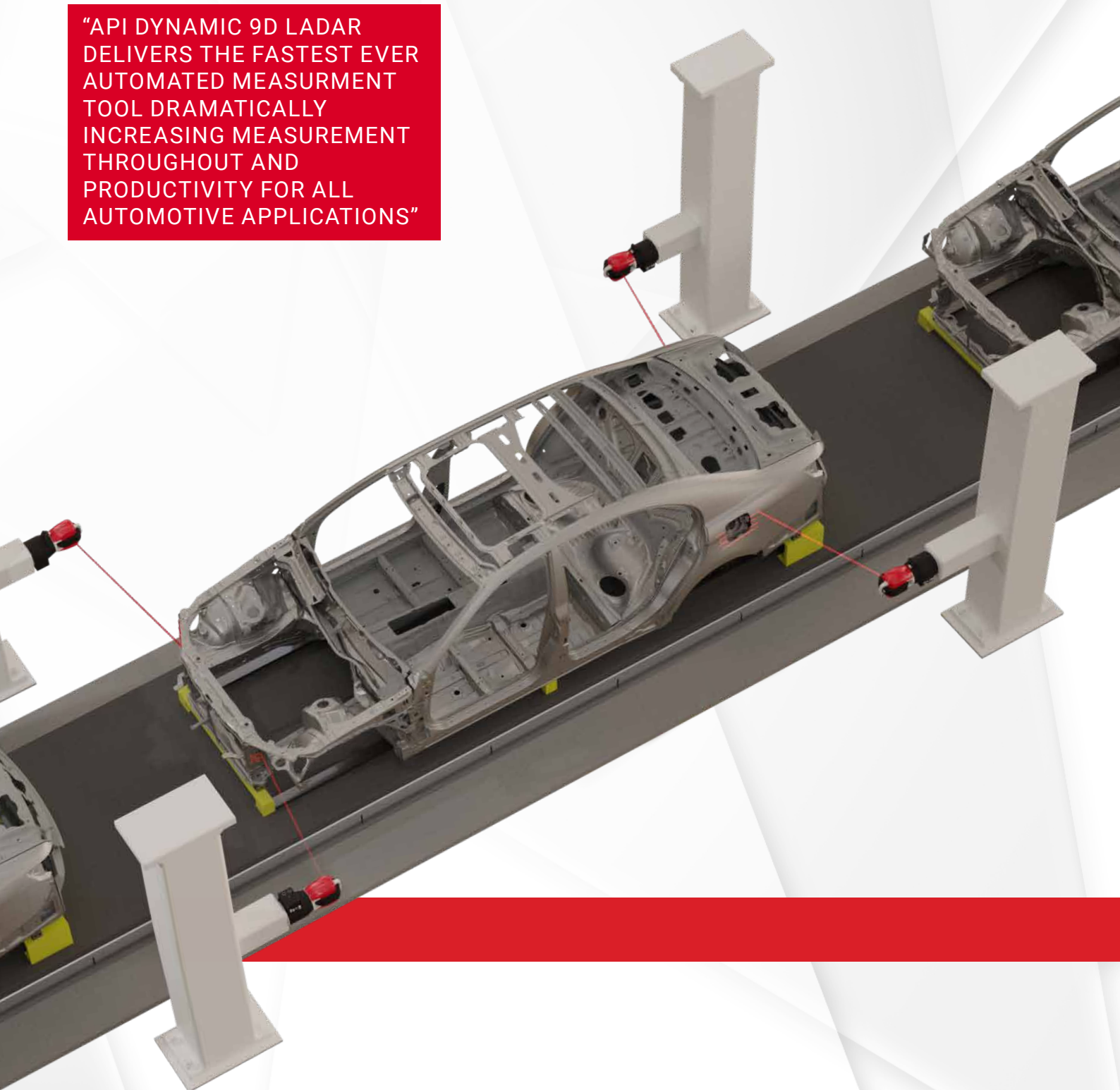

AUTOMATED CMM MEASUREMENT

The Coordinate Measuring Machine (CMM) remains a workhorse of manufacturing organizations due to its benchmark accuracies. Typically, CMMs are isolated away from the manufacturing floor, due to their inability to pace production, and they are typically only used for audit inspection tasks. 9D LADAR can be seamlessly integrated with a large volume gantry or bridge style CMM or can be retrofitted, converting an existing tactile CMM to a high-speed optical solution, negating complex CMM programming and decreasing CMM measurement cycles times 10-fold.

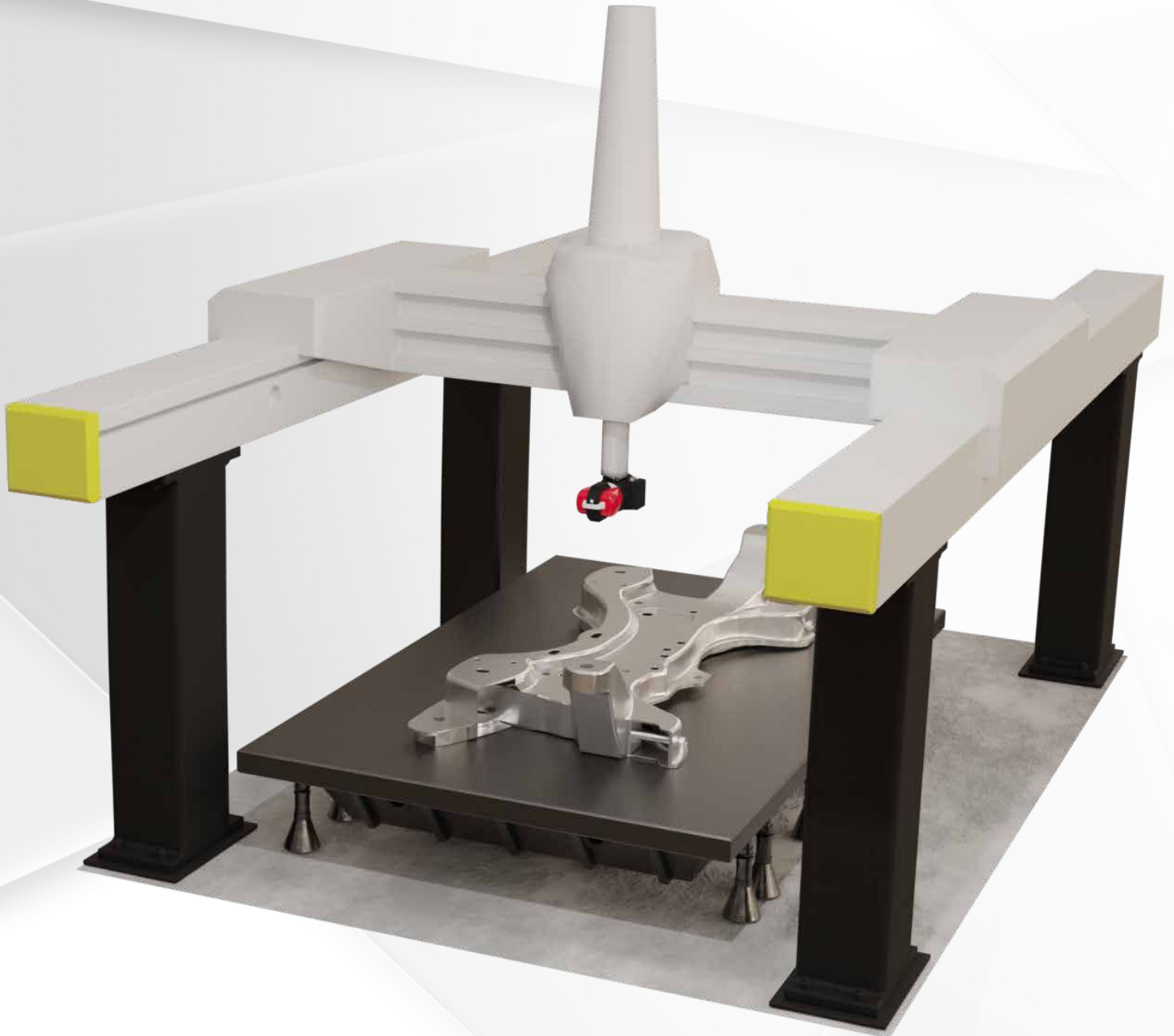

9D LADAR TRACKING AND CALIBRATION

Robot mounted Laser Radar measuring systems have traditionally been calibrated and robot positional accuracy compensated using 'tooling balls', limiting programmable calibrated robot poses, with the loss of measurement flexibility. API offers Dynamic Tracking of robot positioning using its 6DoF RADIAN Laser Tracker providing accurate real-time robot positioning and, unlimited calibrated robot poses. For applications where customers select tooling ball calibration the high dynamics of the 9D LADAR gimbal, along with high scanning rate, ensures that non-productive sphere calibration times are dramatically reduced, optimizing measuring cycle times.

MEASUREPRO SOFTWARE

9D LADAR measurement scanning path is automatically generated within API's MeasurePro software which also captures the generated point cloud data real-time with dynamic on-screen representation. Physical part alignment, imported CAD part feature extraction, and surface scanning regions of interest are generated seamlessly. Geometrical analysis of features and surfaces from point cloud data can be performed directly in MeasurePro, or inside a third-party software such as Polyworks, Metrolog X4, Verisurf, etc, along with the creation of a digital twin of the measured part by direct comparison with nominal part CAD data.

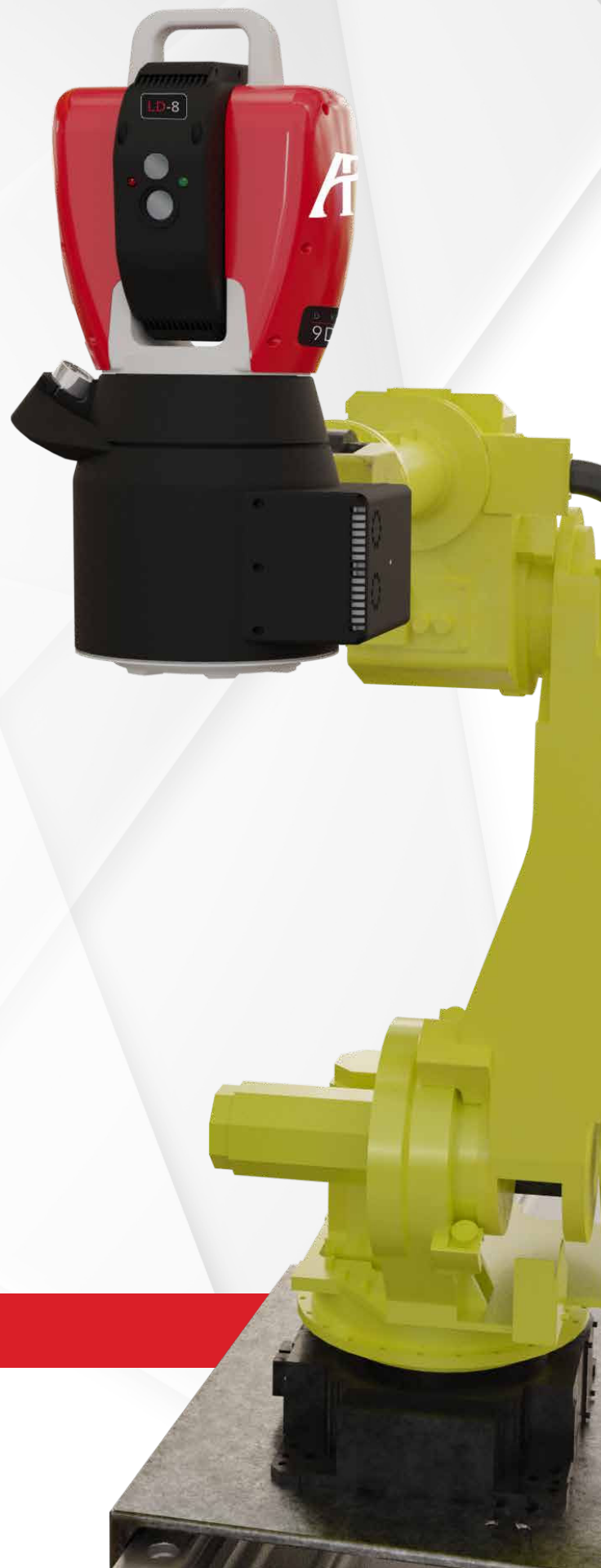

DYNAMIC 9D LADAR TECHNICAL SPECIFICATIONS

MODELS	LD-8; LD-15; LD-25
MEASURING RANGE	LD-8: 0.5M TO 8M • LD-15: 1.0M TO 15M: • LD-25: 1.5M TO 25M
LINEAR ACCURACY (MPE)	25µm + 2µm/m
3D ACCURACY (MPE)	25µm + 6µm/m
INCIDENCE ANGLE	≥85-degree
GIMBAL ANGULAR RANGE	Azimuth: +/- 320° • Elevation: 46° - 69.4°
DYNAMIC PERFORMANCE	Maximum Radial Velocity 180°/sec • Maximum Radial Acceleration 180°/sec ²
TOTAL WEIGHT	10.4kg
CONTROLLER	Fully Integrated
OVERALL DIMENSIONS	191mm (W) x 254mm (L) x 432mm (H)
MAXIMUM DATA RATE	20,000 points/second, 50 lines/second (vertical scans)
TRANSVERSE RESOLUTION	0.05mm to 10mm horizontal spacing
VISION CAMERA	8 MP Digital Zoom (15fps) • Features Recognition • FoV - Horizontal 17° Vertical 13°
LASER SAFETY RATING	Measuring: Class 1 (Wavelength 1550nm)
WARM-UP TIME	20 minutes (typical)
INGRESS PROTECTION RATING	IP52

	2 Point Length Measurement Accuracy* $MPE (\mu m) = \sqrt{2(20+5R_{AVE})^2 + 2(13.6R_{AVE})^2}$							
Average Range (m)	0.5	1	2	5	10	15	20	25
MPE (µm)	56	56	56	85	170	255	340	425
Typical (µm)	28	28	28	43	85	128	170	213

*Accuracy given as Maximum Permissible Error (MPE) in accordance with ASME B89.4 - 2006 verified in vertical orientation at 20°C. Typical accuracy shown is half MPE. All measurements taken in stable environment with 1/2" grade 25 or better tooling ball.



15000 JOHNS HOPKINS DRIVE, ROCKVILLE, MD, 20850, USA
PHONE: 240.268.0400 • INFO@APIMETROLOGY.COM
APIMETROLOGY.COM

API EUROPE
+49 (0) 6221-729-805-0
INFO.EU@APIMETROLOGY.COM

API CHINA
+86 10-59796858
API-CN@APIMETROLOGY.COM

API BRASIL
+55 12-3209-0675
API-BR@APIMETROLOGY.COM

API INDIA
+91 020.4860.7480
API-IN@APIMETROLOGY.COM