

FS Series Femtosecond Lasers

www.photonix.com

With tens of thousands of lasers shipped worldwide, Photonics Industries introduces its FS Series of femtosecond (fs) lasers. With true fs pulse widths, ~ 400 fs, it delivers the smallest heat affected zone (HAZ) compared to other "sub ps" (e.g., ~ 800 fs) lasers also marketed as femtosecond lasers. Furthermore, the FS Series lasers, with its new revolutionary packaging has smaller form factor and higher performance compared to other fs laser competitors.



The FS provides from 5W to 100W of IR (GRN, UV and DUV outputs also available) on the simplest, most compact AIO (All-in-One) platform with up to 40MHz PRF output for processing at highest throughput with polygon scanners.

The user-friendly control interface allows Total Pulse Control and Burst Mode operation, where a user selectable number of pulses with adjustable incremental separation and programable amplitude can be released in an envelope, further enabling ablation rate increases on many materials. With adjustable repetition rate, the user can change the operating PRF and change the operating power or pulse energy through PEC (Power or Pulse Energy Control) function on the fly to maximize process flexibility.

Applications

- Ultrafast high precision cutting, drilling, welding, scribing, marking, intra-marking, patterning, de-paneling, repair
- Flat Panel Display Repair, LCD/LED/OLED Repair
- Hydrophobic Material Manufacturing, Hydrophilic Material Manufacturing, Ultrafast Laser Assisted Etching (ULAE) Systems, Complex 3D Surface Micro-structuring
- Terahertz (THz) Generation, High Harmonic Generation (HHG), X-Ray Generation, OPO Amplifier Systems
- Laser Particle Accelerator Systems
- Angle/Time-resolved Photoemission Spectroscopy Systems, Femtosecond-stimulated Raman Spectroscopy (FSRS) Systems, Multi-photon Fluorescence Microscopy Systems

Features

- High power laser (up to 100 W in IR) with ultra-short pulse (~ 400 fs)
- Specifiable pulse width
- Wide range of wavelengths: 1030 nm, 515 nm, 343 nm, and 257 nm available upon request.
- The most compact, rugged, all-in-one fs laser
- Pulse repetition rates up to 40MHz
- Excellent TEM00 beam with typical M2 ~ 1.2
- Exceptional Beam Pointing Stability $< 20 \mu\text{rad}$
- PEC (Power or Pulse Energy Control)
- PSO (Position Synchronized Output) support for external triggering to any arbitrary PRF while maintaining a constant, stable pulse energy with low jitter.
- Burst Mode for individually controllable bursts of pulses with variable separations.
- POD (Pulse-On-Demand), where a burst of pulses with separation equal to the PRF, can be triggered internally, externally, or continuously, while maintaining constant pulse energy.
- Air-cooled option available

Specifications

	FS1-1030-5	FS1-1030-25	FS1-1030-50	FS2-1030-75	FS2-1030-100
Beam and output specifications					
Wavelength	1030 ± 8 nm				
Average power	5 W at 100 kHz	25 W at 1 MHz	50 W at 1 MHz	75 W at 1 MHz	100 W at 1 MHz
Maximum pulse energy	50 µJ	25 µJ	50 µJ	75 µJ	100 µJ
Pulse width ¹	< 350 fs to 20 ps			< 450 fs to 20 ps	
Pulse repetition rate ²	Single shot to 2 MHz (option up to 40 MHz)				
Pulse-to-pulse stability at 1 MHz	~2% rms				
Long term power stability, 8h ± 1°C	≤ 1% rms				
Beam spatial mode	TEM ₀₀ M ² < 1.2				
Beam pointing stability	< 20 µrad				
Operational specifications and system characteristics					
Interface	RS232, Ethernet, Software GUI, External TTL Triggering				
Warm-up time	< 20 minutes				
Electrical requirement	100-240 V AC; or 32 V DC, 15 A				
Line frequency	50-60 Hz				
Climate	Ambient 15°C to 30°C (59°F to 86°F) Operating Range, Relative Humidity 90% Maximum, non-condensing				
Power consumption	< 600 W			< 800 W	
Dimensions (LxWxH)	25 x 10 x 4.25 in.			28.25 x 10 x 4.25 in.	
Weight	~75 lbs			~85 lbs	
Vibration	Up to 3g				
Cooling system ³	Closed-loop chiller				

1. Specifiable pulse width.

2. Lower repetition rates, down to single shot, achieved by utilizing PSO or POD features.

3. Air-cooled option available for low power FS Series models. Please contact us for more information.

Pulse energy (µJ) as a function of pulse repetition rate (kHz)

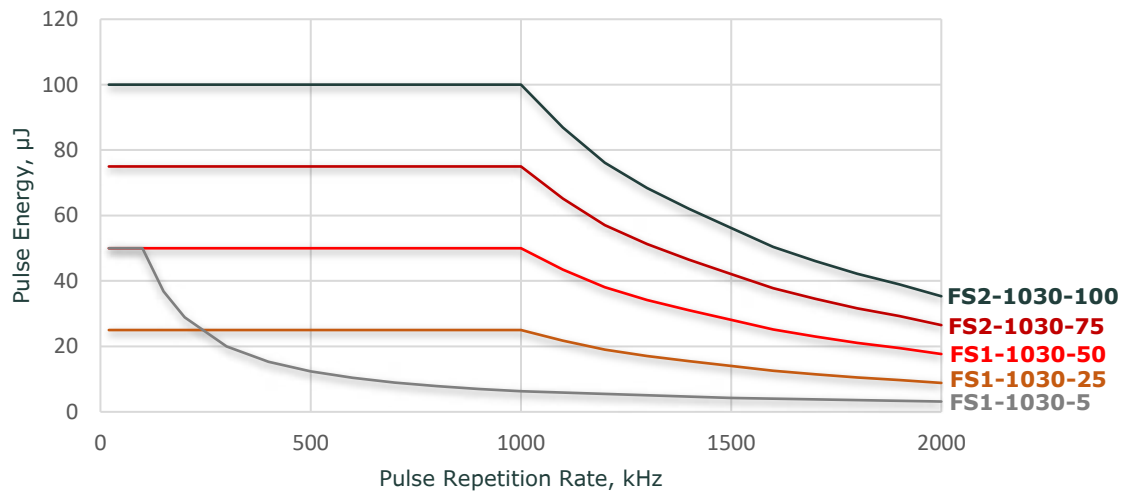

	FS1-515-2.5	FS1-515-15	FS1-515-30	FS2-515-40	FS2-515-55
Beam and output specifications					
Wavelength	515 ± 4 nm				
Average power	2.5 W at 100 kHz	15 W at 1 MHz	30 W at 1 MHz	40 W at 1 MHz	55 W at 1 MHz
Maximum pulse energy	25 µJ	15 µJ	30 µJ	40 µJ	55 µJ
Pulse width ¹	< 350 fs to 20 ps			< 450 fs to 20 ps	
Pulse repetition rate ²	Single shot to 2 MHz (option up to 40 MHz)				
Pulse-to-pulse stability at 1 MHz	< 2.5% rms				
Long term power stability, 8h ± 1°C	≤ 1% rms				
Beam spatial mode	TEM ₀₀ M ² ≤ 1.2				
Beam pointing stability	≤ 25 µrad				
Operational specifications and system characteristics					
Interface	RS232, Ethernet, Software GUI, External TTL Triggering				
Warm-up time	< 20 minutes				
Electrical requirement	100-240 V AC; or 32 V DC, 15 A				
Line frequency	50-60 Hz				
Climate	Ambient 15°C to 30°C (59°F to 86°F) Operating Range, Relative Humidity 90% Maximum, non-condensing				
Power consumption	< 600 W			< 800 W	
Dimensions (LxWxH)	25 x 10 x 4.25 in.			28.25 x 10 x 4.25 in.	
Weight	~75 lbs			~85 lbs	
Vibration	Up to 3g				
Cooling system ³	Closed-loop chiller				

1. Specifiable pulse width.

2. Lower repetition rates, down to single shot, achieved by utilizing PSO or POD features.

3. Air-cooled option available for low power FS Series models. Please contact us for more information.

Pulse energy (µJ) as a function of pulse repetition rate (kHz)

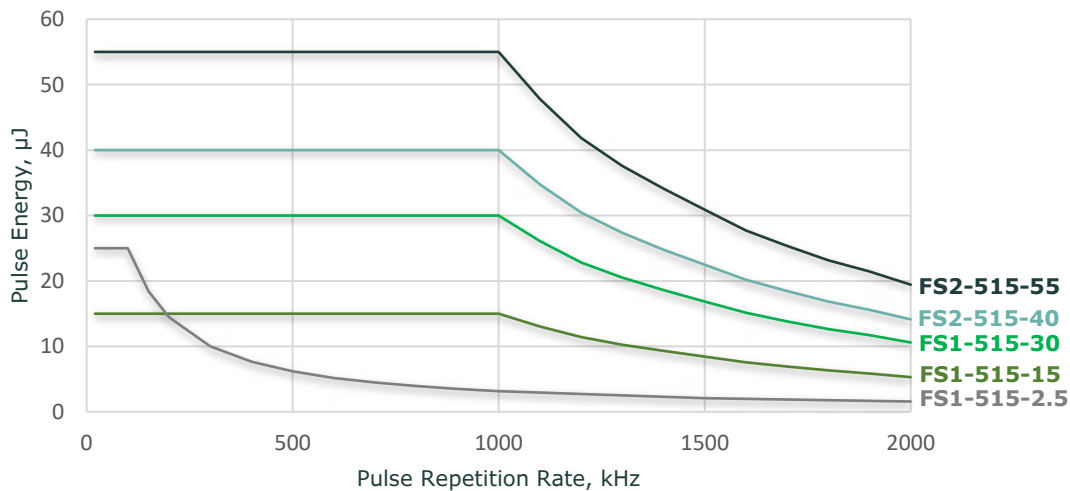

	FS1-343-2	FS1-343-10	FS1-343-15	FS2-343-20	FS2-343-30
Beam and output specifications					
Wavelength	343 ± 3 nm				
Average power	2 W at 100 kHz	10 W at 1 MHz	15 W at 1 MHz	20 W at 1 MHz	30 W at 1 MHz
Maximum pulse energy	20 µJ	10 µJ	15 µJ	20 µJ	30 µJ
Pulse width ¹	< 350 fs to 20 ps			< 500 fs to 20 ps	
Pulse repetition rate ²	Single shot to 2 MHz (option up to 40 MHz)				
Pulse-to-pulse stability at 1 MHz	~3% rms				
Beam spatial mode	TEM ₀₀ M ² < 1.3				
Beam pointing stability	≤ 30 µrad				
Operational specifications and system characteristics					
Interface	RS232, Ethernet, Software GUI, External TTL Triggering				
Warm-up time	< 20 minutes				
Electrical requirement	100-240 V AC; or 32 V DC, 15 A				
Line frequency	50-60 Hz				
Climate	Ambient 15°C to 30°C (59°F to 86°F) Operating Range, Relative Humidity 90% Maximum, non-condensing				
Power consumption	< 600 W			< 800 W	
Dimensions (LxWxH)	25 x 10 x 4.25 in.			28.25 x 10 x 4.25 in.	
Weight	~75 lbs			~85 lbs	
Vibration	Up to 3g				
Cooling system ³	Closed-loop chiller				

1. Specifiable pulse width.

2. Lower repetition rates, down to single shot, achieved by utilizing PSO or POD features.

3. Air-cooled option available for low power FS Series models. Please contact us for more information.

Pulse energy (µJ) as a function of pulse repetition rate (kHz)

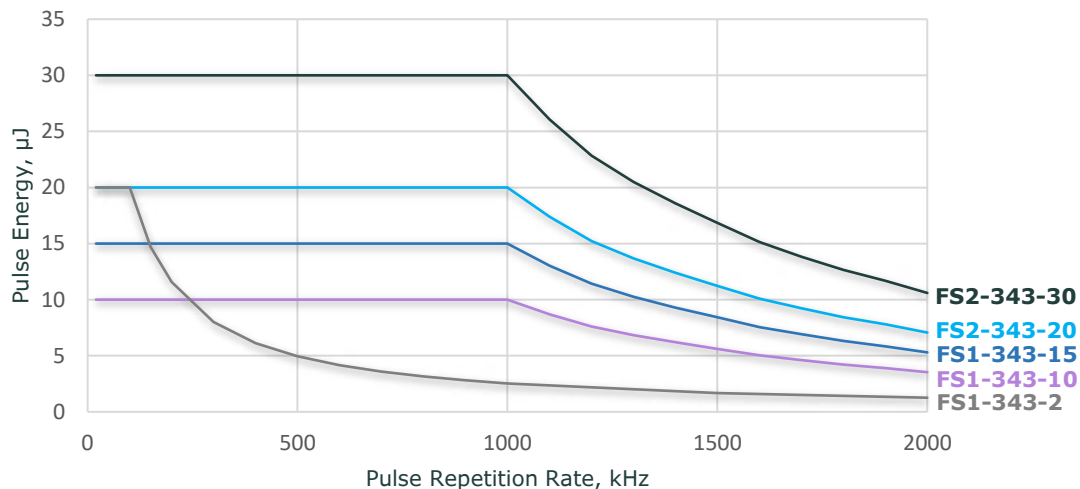

Features

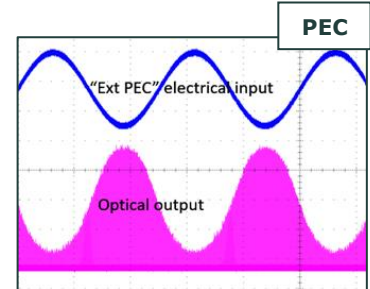
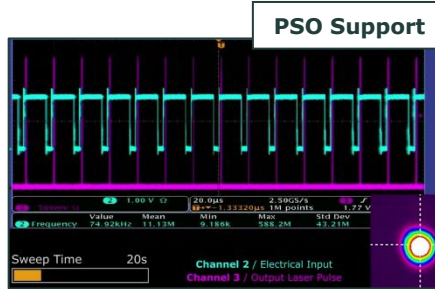
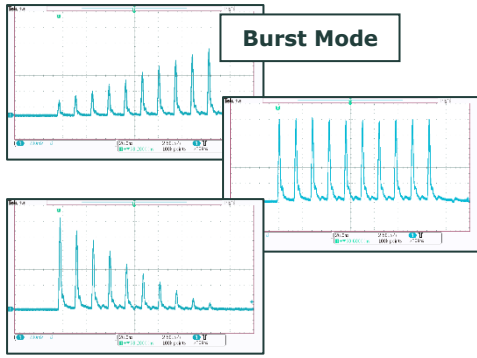

Dimensional Drawings

FS1-1030-5, FS1-1030-25, and FS1-1030-50
FS1-515-2.5, FS1-515-15, and FS1-515-30
FS1-343-2, FS1-343-10, and FS1-343-15

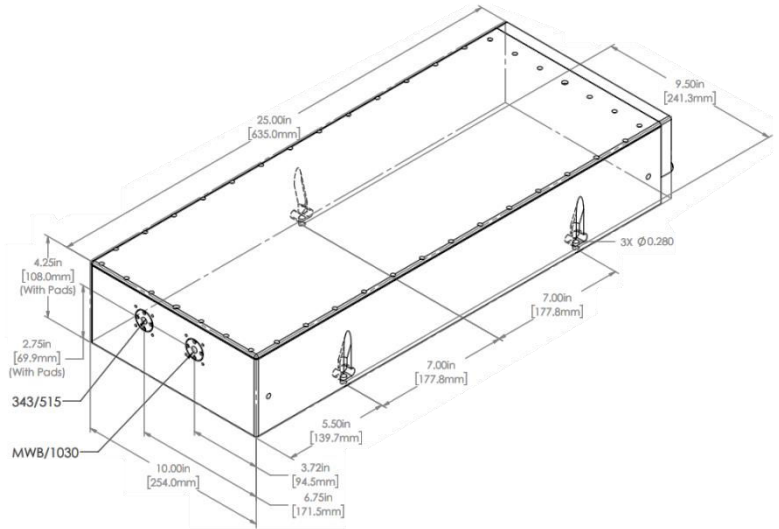

Photonics Industries FS Series femtosecond lasers are all-in-one (AIO) and do not require a separate controller or utility module. All connections for operation and control of the laser can be found on the back panel of the AIO laser.

FS2-1030-75, and FS2-1030-100
FS2-515-40, and FS2-515-55
FS2-343-20, and FS2-343-30

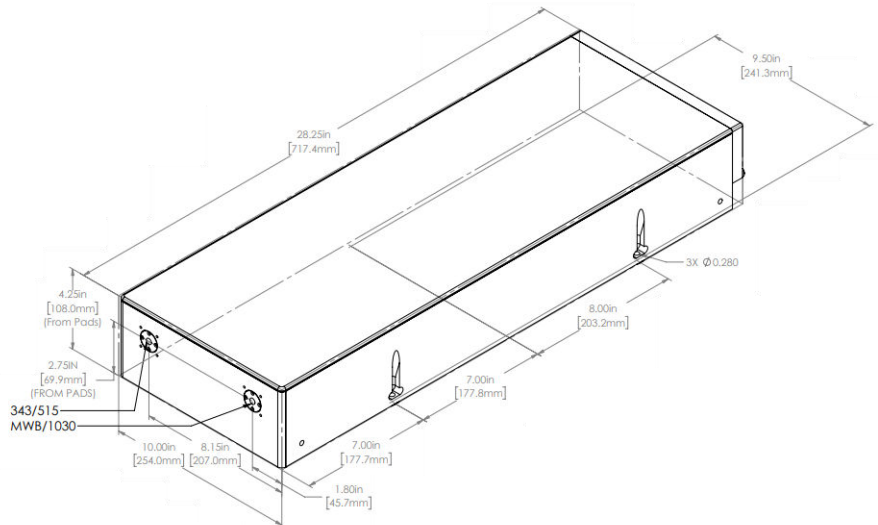

Due to Photonics Industries' commitment to continuous product improvement, specifications and drawings are subject to change without notice.

Photonics Industries conforms to provisions of US 21 CFR 1040.10 & 1040.11 and is made under one or more US patents listed below: 9,531,147, 8,817,831, 7,869,471, 7,346,092, 7,082,149, 7,079,557, 6,999,483, 6,980,574, 6,961,355, 6,842,293, 6,762,405, 6,690,692, 6,587,487, 6,584,134, 6,366,596, 6,356,578, 6,327,281, 6,246,707, 6,229,829, 6,108,356, 6,061,370, 6,028,620, 5,936,983, 5,898,717 and Pending Patents
 R.051722

Copyright © 2022 by Photonics Industries International, Inc.

Main Headquarters: 1800 Ocean Ave, Ronkonkoma, New York 11779, United States

Photonics Industries International is the pioneer of intracavity harmonic lasers and is at the forefront of developing, manufacturing and marketing a wide range of nanosecond, sub-nanosecond, picosecond and femtosecond lasers for industrial, scientific, defense, and medical industries. Check out our [products](#) and see how we can help you [apply](#) our lasers to your needs.

[Website](#) - [Products](#) - [Applications](#) - [Company](#) - [Contact](#) - [International Network](#)

