



C321 Airborne Back

# PHANTOM Miro<sup>®</sup> C321 Airborne

AIRBORNE  
HIGH-SPEED CAMERA

Tested to Aerospace Specs  
1,480 fps at full HD (1920 x 1080) resolution  
Operates to -55°C

## FEATURES & BENEFITS

### DESIGNED SPECIFICALLY FOR AIRBORNE APPLICATIONS

- The C321 Airborne camera leverages the rugged and proven design of the C321 vehicle crash test camera, with additional testing to stringent Aerospace specifications.
- The C321 Air is temperature tested to -55°C and all PC boards are conformal coated, providing high quality HD images in the most demanding environments.
- Use secured, removeable Flash to keep data safe, and Auto-Save to Flash to quickly save shots.
- 16GB of RAM provides over 13 seconds of record time at 500 fps at full HD resolution of 1920 x 1080, and much more record time as smaller resolutions. 63 partitions allow for multiple shots.
- Passive cooled to mitigate vibration.

### FLEXIBLE AND EQUIPPED WITH FULL PHANTOM FEATURES

- High image quality with low noise and high dynamic range to capture critical detail.
- Robust signaling with Programmable IO, including FSYNC, IRIG and STROBE and more increases the C321 Air's flexibility to meet specific workflows, timing and synchronization requirements.
- Increase frame rates by reducing resolutions. Test other critical phenomena with the same powerful camera.

## IMAGE & SENSITIVITY

Sensor Type	CMOS, with Global Shutter
Maximum Resolution	1920 x 1080
CAR Increments	640 x 8
Pixel Size	10 $\mu$ m
Sensor Size	19.2 x 10.8 mm; 22.03 mm diagonal
Bit Depth	10-bit
<b>EMVA 1288 Measurements (at 532 nm)</b>	
Quantum Efficiency %	45.3% Mono 31.5% Color
Max. SNR (dB)	37.4
Absolute Sensitivity Threshold (p)	33.5 Mono 43.3 Color
Saturation Capacity (e <sup>-</sup> )	5501 Mono 5311 Color
Temporal Dark Noise (e <sup>-</sup> )	14.55
Dynamic Range (dB)	51.2

- Reported measurements were taken at 532 nm with both monochrome and color cameras
- Visit: [www.phantomhighspeed.com/emva](http://www.phantomhighspeed.com/emva) for more information on EMVA 1288

## SPECTRAL RESPONSE

### Quantum Efficiency Monochrome and Color

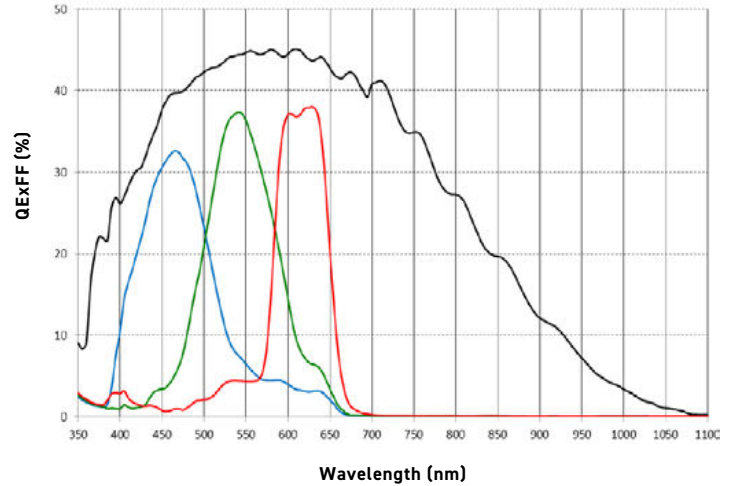

## CONNECTIVITY & SIGNALS

	C321 Air
Ethernet	Gb Ethernet accessed through Fischer Connector
Timecode	IRIG In- Modulated/Unmodulated; IRIG Out - Unmodulated
Port Descriptions	Fischer 12-Pin Capture port, for Trigger, IRIG In/Out, Strobe, Event, Memgate, FSYNC, READY Out, and Programmable IO Signals from MiniBoB
	Fischer 8-Pin Gb Ethernet
	Fischer 6-Pin Power
IO Signals	Programmable I/O for Fsync, Strobe, Ready, Timecode-out, Event, Memgate, Pretrigger. Assign and define signals in PCC
Hardware Trigger	Capture port, to MiniBoB
Software Trigger	via PCC over Ethernet; via Image Based Auto trigger (IBAT)
Synchronization	External Sync via FSync or IRIG Timecode
Recording Features	Burst mode, Continuous recording & AutoSave to internal Flash
Video Output	HD-SDI





When it's too fast to see, and too important not to.®

Miro® C321 Airborne DATASHEET

MEMORY & STORAGE	
RAM Buffer	16GB RAM
Multi-Cine	Up-to 63 Partitions
Non-Volatile	External, removable Flash capability

FRAME RATES & EXPOSURE	
Top FPS at Max Resolution	1,480
Maximum FPS	94,510
Minimum FPS	50
CAR Increments	640 x 8
Minimum Exposure	1 $\mu$ s
PIV Features	Shutter-off mode straddle time = 1180ns Supports Burst Mode
Exposure Features	Auto Exposure



### FRAME RATE CHART

Table provides examples of common resolutions and frame rates.

Maximum Frame Rate - FPS; (16GB Record Time - Sec)	
Resolution (H x V)	Standard Mode
1920 x 1080	500 (13.25)
1920 x 1080	1,480 (4.48)
1920 x 800	1,990 (4.50)
1280 x 1024	1,560 (6.72)
1280 x 512	3,090 (9.78)
640 x 480	3,290 (13.6)
640 x 128	11,765 (14.32)
640 x 64	22,070 (15.2)
640 x 8	94,510 (28.4)



## CONTROL

Software & OS	Phantom PCC (Windows x64); SDK available for C/C++, C#, Python, MatLab and LabView
Primary File Format	Phantom Cine RAW (.cine)
Alternative File Formats	Easily convert to formats including .mp4, Apple ProRes .mov, .avi, Tiff, JPG, DNG and many more using PCC Cine files are directly compatible with many major video editing and motion analysis programs
Highlighted Software Features	"Set New CSR Default" for stable black reference, Auto-Save to Flash, Continuous recording, Advanced Image Tools and Processing

## POWER

AC Power	100-250 VAC, 40W power supply included
Voltage Range	16-36VDC
Power Consumption	14W typical

## MECHANICAL

Size	2.9 x 2.9 x 4.2" (73 x 73 x 107 mm)
Weight	1.2 lbs (0.54 kg)
Lens Mounts	1" C-Mount, for 4/3" lens
Mounting Points	4 x 1/4-20, 16 x M4 x 0.7
Cooling	Passive cooling

## ENVIRONMENTAL

Operating Temperature	-55 to +50°C
Storage Temperature	-55 to +71°C
Operational Shock	170G, 6msec sawtooth, 3 axes, 2 directions per axis, 10 shock per direction (60 pulses total) (without lenses)
Regulatory	<b>Emissions</b> – CE Compliant EN 61326-1, Class A <b>Immunity</b> – CE Compliant EN 61326-1, Class A <b>FCC</b> – CFR 47, Part 15, Subpart B & ICES-003, Class A <b>Safety</b> – IEC 60950-1 (2012)

### Airborne Environmental Tests: *(pending)*

IAW MIL-STD-810H:	
Temperature: Methods 501.7/502.7	-55 to +50°C
Altitude: Method 500.6	50,000ft Storage/Operation
Shock: Method 516.8	20g Operation; 40g Crash
Vibe: Method 514.8, Category 12	20 grms
Humidity: Method 407.6	95% RH
Power	MIL-STD-704F, 28VDC
EMI	MIL-STD-461E

## GLOBAL SUPPORT NETWORK

Phantom cameras are supported by Vision Research's Global Service and Support network, providing PhantomCare services from multiple sites around the globe.

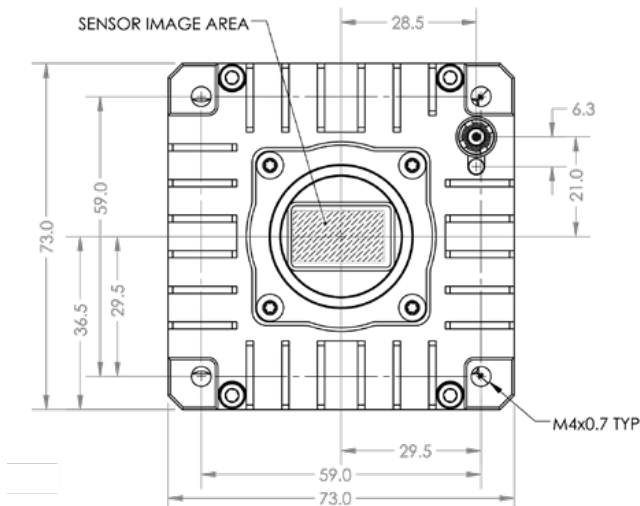

### ABOUT VISION RESEARCH

Focused. Since 1950, Vision Research has been designing, and manufacturing high-speed cameras. Our single focus is to invent, build, and support the most advanced cameras possible.



100 Dey Road  
Wayne, NJ 07470 USA  
+1.973.696.4500