

# PHANTOM C540J C980J JB3

HIGH-SPEED CAMERA SYSTEM



2560 × 1680 up to 1,140 fps (C540J)  
3840 × 2160 up to 1,180 fps (C980J)



## FEATURES & BENEFITS

### UNCOMPROMISING IMAGE QUALITY

- Both cameras feature BSI CMOS sensor architecture with correlated double sampling (CDS) to deliver ultra-low read noise for clean and reliable images in low-light and high contrast applications
- Choose the 1" 4 Mpx sensor (C540J) for compact installations due to lens selection
- Choose the 4/3" 8 Mpx sensor (C980J) for higher spatial resolution and wider fields of view

### GREATER SYSTEM FLEXIBILITY & SCALABILITY

- The new system is designed around the JB3 Junction Box, which routes signals, synchronizes camera data, and connects the cameras into a unified system, supporting up to 8 cameras per JB3
- JB3 Includes 10Gb Ethernet for faster data download

### ENGINEERED FOR REAL-WORLD TESTING

- Both cameras and the JB3 Junction Box are rated for repeated shocks up to 170G-making the system suitable for crash and sled testing
- The compact, rounded camera form factor and lightweight 0.6 lbs camera body allow installation in tight spaces and confined test environments

IMAGE & SENSITIVITY		
Sensor Type	Proprietary BSI CDS CMOS designed by Forza Silicon, Global Shutter	
Maximum Resolution	<b>C540J:</b> 2560 × 1680	<b>C980J:</b> 3840 × 2160
CAR Increments	1920 × 24	
Pixel Size	5 μm	
Sensor Size (Diagonal)	<b>C540J:</b> 15.3 mm 1" format	<b>C980J:</b> 22 mm 4/3" format
Bit Depth	12-bit	
	EMVA 1288 Measurements (at 533 nm)	
	C540J	C980J
Quantum Efficiency (QExFF) (%)	60.7 mono 62.6 color	57.7 mono 63.1 color
Max. SNR (dB)	37.8	37.3
Absolute Sensitivity Threshold (e-)	4.89 mono 4.75 color	4.69 mono 4.58 color
Saturation Capacity (e-)	6058 mono 6015 color	5431 mono 5424 color
Temporal Dark Noise (e-)	4.33	4.14
Dynamic Range (dB)	61.87	61.27

- Reported measurements were taken at 533 nm with both monochrome and color cameras, using the EMVA 1288 4.0 standard  
 - Visit: [www.phantomhighspeed.com/emva](http://www.phantomhighspeed.com/emva) for more information on EMVA 1288

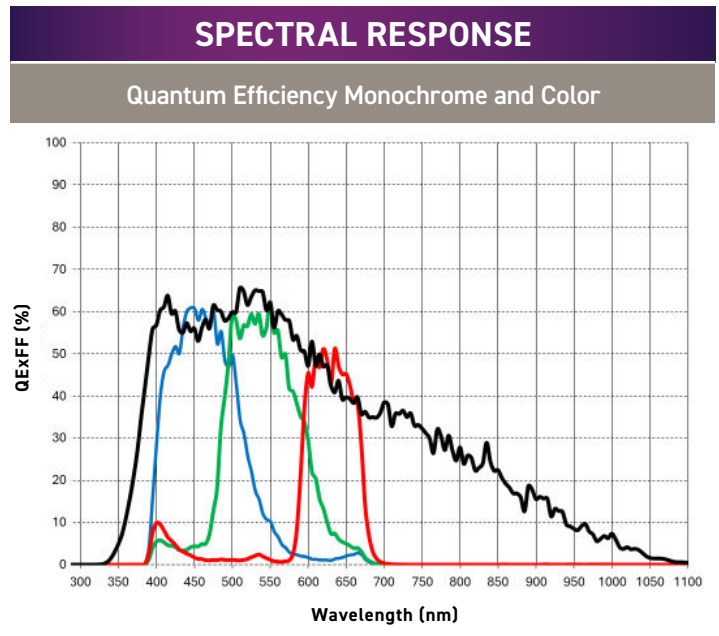

CONNECTIVITY & SIGNALS	
Ethernet	Gb / 10Gb Ethernet accessed through JB3
Timecode	IRIG-B
Port Descriptions	Camera connects to JB3 with built-in system cable, up to 10M. Extension cables are available for longer lengths. JB3 Junction box includes 8 camera ports, 1 Power input, Sync-in port, Sync-out port, 2 Ethernet ports (Gb/10G), and 3 BNC ports for I/O signals
I/O Signals	Trigger, Ready, External FSync, IRIG-B input
Hardware Trigger	Trigger port on JB3
Software Trigger	via PCC over Ethernet
Synchronization	External Sync via FSync or IRIG-B Timecode
Recording Features	Burst mode, Continuous Recording, Auto Save to internal Flash
Video Output	3G SDI via Din connector on camera front
Accessory Power	N/A



MEMORY & STORAGE		
RAM Buffer	<b>C540J:</b> 14 GB	<b>C980J:</b> 28 GB
Capture Duration	1.9 seconds at max resolution and max frame rate	
Multi-Cine	Up-to 63 Partitions	
Non-Volatile Media	256 GB internal SD flash memory	
Media Transfer Rates	60 MB/s from RAM to internal SD flash	

FRAME RATES & EXPOSURE		
Top FPS at Max Resolution	<b>C540J:</b> 1140	<b>C980J:</b> 1180
Maximum FPS	<b>C540J:</b> 50,820	<b>C980J:</b> 50,820
Minimum FPS	100	
Frame Timer Clock	68 Mhz	
Minimum Exposure	3 μs	
PIV Features	N/A	
Exposure Features	Auto Exposure	

## FRAME RATE CHART

Table provides examples of common resolutions and the maximum frame rate.

MAXIMUM FRAME RATE - FPS		
Resolution (H × V)	C540J	C980J
3840 × 2160	N/A	1,180
3840 × 1020	N/A	2,460
3840 × 780	N/A	3,200
2560 × 1680	1140	1,510
2560 × 1500	1,280	1,690
2560 × 1140	1,670	2,210
2560 × 720	2,620	3,450
2560 × 72	20,500	26,130
1920 × 1680	1,510	1,510
1920 × 1200	2,100	2,100
1920 × 1140	2,210	2,210
1920 × 1080	2,330	2,330
1920 × 1020	2,460	2,460
1920 × 672	3,690	3,690
1920 × 384	6,280	6,280
1920 × 24	50,820	50,820

**CONTROL**

Software & OS	Phantom PCC-3 and PCC-4 (Windows x64) for control; Phantom Cine Analyzer for analysis; SDK available for C/C++, C#, Python, MatLab and LabView
On-Camera Controls	N/A
Primary File Format	Phantom Cine RAW (.cine)
Alternative File Formats	Easily convert to formats including .mp4, .avi, and Tiff using PCC. Cine files are directly compatible with many video editing and motion analysis programs
Software Features	"Set New CSR Default" for fixed black reference, Auto-Save to Flash, Continuous recording, Advanced Image Tools and Processing

**MECHANICAL**

Housing Variants	N/A	
Size	<b>C540J:</b> 6.2 × 6.2 × 6.35 cm	<b>C980J:</b> 6.2 × 6.2 × 5.77 cm
Weight	0.6 lb (0.27 kg)	
JB3 Junction Box Size	6.8 × 3.2 in (17.2 × 8.2 cm)	
JB3 Junction Box Weight	1.6 lbs (0.7 kg)	
Lens Mounts	C-mount	
Mounting Points	1/4x20 and M4 mounting points on all sides	
Internal Shutter	N/A	
Cooling	Active cooling	

**POWER**

AC Power	JB3 Junction box uses 280W power supply. Cameras are powered from JB3	
Voltage Range	20-36 VDC	
Power Consumption	<b>C540J:</b> 31W @ 24V (through the JB3 + 5M cable)	<b>C980J:</b> 28W @ 24V (through the JB3 + 5M cable)
Battery Options	C540J includes 700V 750mA Lithium-ion Battery for backup	

**ENVIRONMENTAL**

Operating Temperature	0 to +50°C
Storage Temperature	-20 to +70°C
Operating Humidity	5% - 95%
Operational Shock	Preliminary 170G, sawtooth wave, 6ms, +/- 10 pulses all axes
Operational Vibration	Preliminary 24 Grms, IAW MIL-STD-202G Method 214-A.; Test Condition G, 15 min per axis
Regulatory	<b>Preliminary Emissions</b> - CE Compliant EN 61326-1, Class A <b>Immunity</b> - CE Compliant EN 61326-1, Class A <b>FCC</b> - CFR 47, Part 15, Subpart B & ICES-003, Class A <b>Safety</b> - IEC 60950-1 (2012) <b>KC</b> - TBD

**PHANTOM SERVICES**

Phantom cameras are supported by an array of services engineered for users to get the most out of their Phantom camera, covering every stage from setup to analysis.

**Phantom Care** includes services to maintain optimal camera performance including flexible support plans, camera certification, rentals and upgrades



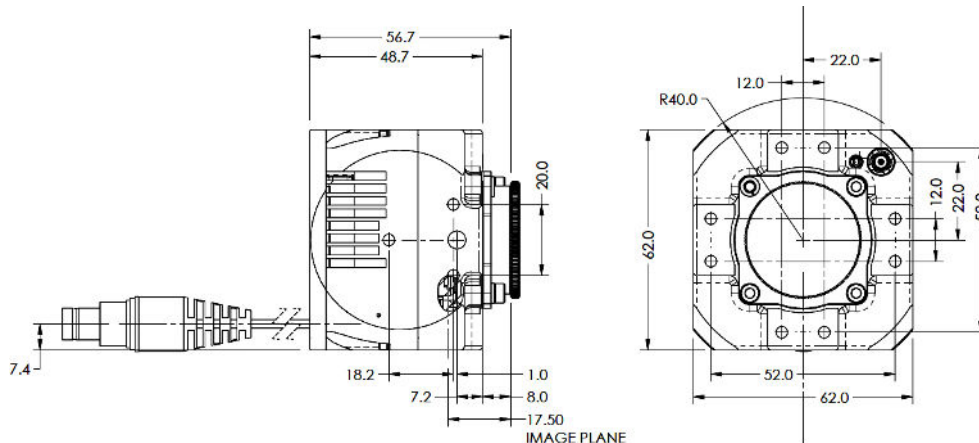

**Phantom Analysis** includes onsite application-specific testing, expert data analysis and custom Python module development

**Phantom Academy** training courses for foundational and advanced applications are available for all experience levels



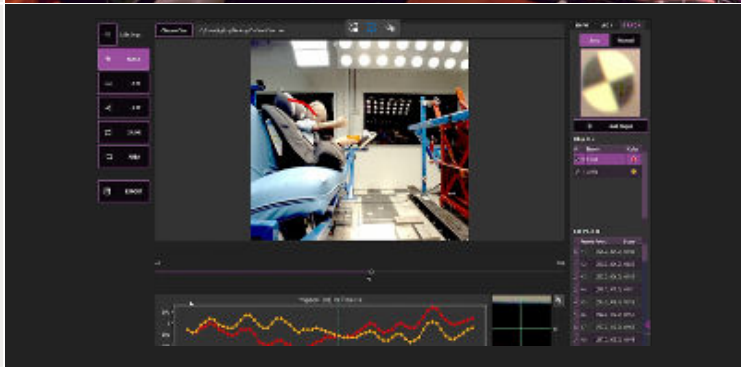
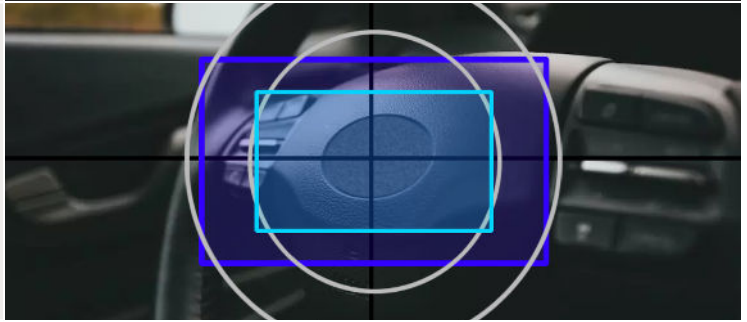

## APPLICATION-SPECIFIC FEATURES

<p>Automotive Crash &amp; Safety Testing</p>	<p>High-resolution, <b>low-noise imaging (4.14 e-)</b> captures clean, detailed slow-motion imagery of crash events from multiple angles, ensuring reliable data for safety analysis and regulatory review.</p>	
<p>Dynamic range control in low-light, space-constrained high-speed imaging</p>	<p>The exclusive <b>4 and 8 Mpx</b> backside illuminated sensors feature correlated double sampling (CDS) achieve <b>over 10 stops</b> of dynamic range. The result is exceptional clarity even in challenging lighting conditions. By preserving image quality at high frame rates and high contrast environments, engineers can capture reliable data for accurate measurement, tracking, and analysis when every detail matters.</p>	
<p>Measure and track the dynamic phases of a crash</p>	<p>Cine raw files from this system are compatible with Phantom CineAnalyzer (PCA) Track &amp; Measure module — transforming high-speed images into precise, measurable motion data. The module enables <b>multi-point tracking with sub-pixel accuracy</b>, allowing engineers to reliably follow complex movements such as component deformation, occupant kinematics, and structural intrusion across high-speed image sequences.</p>	
<p>Engineer a complete system that meets individual test and infrastructure needs</p>	<p>The C980J's <b>4/3" format sensor</b> allows for wider field of view and higher spatial detail, ideal for capturing complex, large-scale crash events. The C540J's <b>1" format sensor</b> supports a more compact optical setup with greater lens availability, allowing flexible placement in confined test environments. The JB3 supports up to 8-cameras per box, cable lengths up to <b>10M direct</b> (30M with adapters), with ability to sync multiple units together for large camera integrations.</p>	
<p>Capturing pedal intrusion and lower-limb motion in the footwell</p>	<p>In one of the tightest and most challenging views in crash testing, this compact <b>6.2 × 6.2 × 6.3 cm</b> design allows the camera to fit cleanly within the footwell without interfering with vehicle structures, test hardware, or occupant motion. Its rounded profile also makes it easier to position close to pedals and lower-limb components, ensuring capture of pedal intrusion and leg kinematics during impact.</p>	

**APPLICATION-SPECIFIC FEATURES**

<p>Integrate directly into established test systems - supporting factory power, triggering, and data workflows</p>	<p>The JB3 Junction Box is backwards compatible with previous Phantom junction box systems, including Miro-JB2, enabling <b>seamless system expansion through daisy chaining</b>. In addition, support for Lemo cable adapters allows straightforward integration with alternative junction and control platforms.</p>	
<p>On-board, Off-board and component testing with unified / broad ecosystem</p>	<p>C-Series camera is rated for <b>170G shock</b> to endure severe crash forces and vibration. The system seamlessly integrates with the entire Phantom camera lineup – including ultra high-speed models over 1,000,000 fps – by leveraging the same PCC control software, .cine file format, and analysis tools. This common platform ensures a consistent workflow and easy scaling, and enables synchronized multi-camera crash imaging without changing software or file handling processes.</p>	
<p>Continuous operation through power interruptions</p>	<p>The C540J includes an <b>on-board, built-in battery</b> to guarantee data capture during power loss, enabling reliable recording in volatile environments. The battery backup allows cameras to remain active after impact, supporting continued operation during post-impact analysis, including post-crash footage review, system checks, and safe data retrieval without immediately restoring vehicle power.</p>	
<p>Structural deformation and intrusion measurement</p>	<p>High-resolution imagery <b>up to 3840 × 2160</b> allows engineers to observe how structures respond to dynamic loading and impact events, revealing deformation behavior, intrusion patterns, and load paths. Visual analysis of these deformation patterns supports improved energy management design and helps identify areas for structural reinforcement or optimization.</p>	

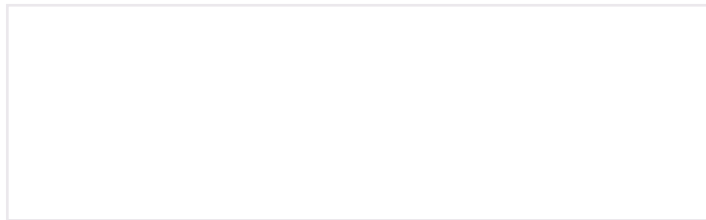

**ABOUT PHANTOM HIGH-SPEED**

Focused. Since 1950, Phantom has been designing, and manufacturing high-speed cameras. Our single focus is to invent, build, and support the most advanced cameras possible.

Phantomhighspeed.com  
+1 973.696.4500  
100 Dey Rd., Wayne,  
NJ 07470, USA  
@PhantomHighSpeed  
@Phantom High-Speed Cameras